

SURLY

Pacer™ Frameset



We've noticed that the availability of affordable steel road bike framesets has diminished substantially over the last few years. So, we decided to do something about it. Meet the Pacer...Surly's all-day road rig.

What makes a bike an all-day bike? Comfort and reliability. Rides like a bike. It's predictable. The Pacer's conservative geometry and tubing spec lend themselves to a full day in the saddle. Of course, it's equally suitable for those short rides to your favorite watering hole. The 4130 TIG-welded frame and brazed fork are designed to take the edge off the bumps and cracks in the road, but remain laterally stiff for those out-of-the-saddle sprints and climbs.

Though vertical compliance is definitely a goal when designing a new frame, tire clearance is just as important. The casings of your tires flex before your frame and fork do, and wide tires generally flex more than narrow ones, giving you a softer ride. Wide tires can be faster than skinnies on a lot of surfaces that you will encounter on your rig. So, the Pacer was designed to accept 700x28c tires with fenders or 700x32c tires without...while allowing you to use standard-reach and long-reach road caliper brakes.

The Pacer is spec'd with a 1-1/8" threadless fork because of the wide selection of headsets and stems available to accommodate it. Like most Surly frames, this one uses commonly available components: 27.2mm seatpost, 68mm bottom bracket, 130mm rear hub... basically, items that you might have lying around, waiting for a chance to be used. We recommend using long reach brakes, but some short reach fit also.

The durability and versatility of the Pacer make it an ideal commuter, day-tripper, and vehicle for exploration. The frame is offered in 9 sizes (42-62cm), so there should be a Pacer that fits you. You won't be disappointed.

Pacer Specifications:

Tubing: 100% Surly 4130 cro-moly steel. Main triangle double-butted. TIG welded

Rear dropouts: Vertical Breeze-In dropouts, 130mm spacing

Braze-ons: Single fender eyelets front and rear, dual water bottle mounts, and pump peg (54cm and larger)

Seatpost diameter: 27.2mm

Seatpost clamp diameter: 30.0mm Surly Constrictor included

Headset: 1-1/8" threadless.

Front Derailleur Clamp Diameter: 28.6mm

Bottom bracket shell: 68mm wide, threaded English 1.37x24t

Tire clearance: Room for 700x32c or 700x28c with fenders

Weight: 56cm = 4.45 lbs. (2.02 kg) Fork - uncut = 2.09 lbs. (.95 kg)

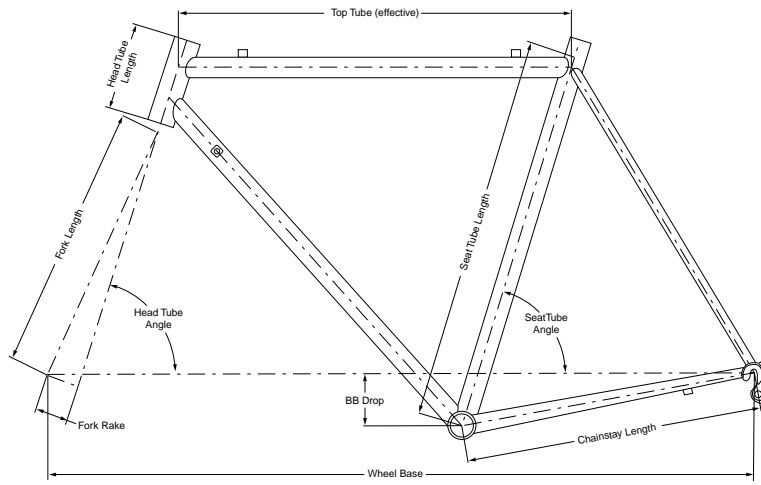

Size	ST (C-T)		TT (C-C)		TT (Effec.)		HT Angle	ST Angle	BB Drop		CS Length		Wheel Base		S.O. Height*		HT Length		FK Length		FK Rake	
	inches	mm	inches	mm	inches	mm	degrees	degrees	inches	mm	inches	mm	inches	mm	inches	mm	inches	mm	inches	mm	inches	mm
42 cm	16.5	420.0	19.4	491.5	19.9	506.0	71.5	75.5	2.8	72.0	16.1	410.0	38.4	974.5	28.2	715.3	3.5	89.0	14.6	371.0	2.0	50.0
46 cm	18.1	460.0	19.9	504.2	20.3	515.0	71.5	75.0	2.8	72.0	16.1	410.0	38.5	978.8	28.9	735.2	4.1	104.0	14.6	371.0	2.0	50.0
50 cm	19.7	500.0	20.7	526.4	20.9	530.0	72.0	74.5	2.8	72.0	16.1	410.0	38.8	985.6	29.8	756.1	4.1	104.0	14.6	371.0	2.0	50.0
52 cm	20.5	520.0	21.3	540.0	21.3	540.0	72.5	74.0	2.8	72.0	16.1	410.0	38.9	987.2	30.2	767.9	4.3	109.0	14.6	371.0	2.0	50.0
54 cm	21.3	540.0	21.7	550.0	21.7	550.0	72.5	73.5	2.8	72.0	16.3	415.0	39.1	992.8	30.9	785.7	4.9	124.0	14.6	371.0	1.8	45.0
56 cm	22.0	560.0	22.2	565.0	22.2	565.0	73.0	73.0	2.8	72.0	16.3	415.0	39.3	998.7	31.6	803.5	5.6	141.0	14.6	371.0	1.8	45.0
58 cm	22.8	580.0	22.8	580.0	22.8	580.0	73.5	73.0	2.8	72.0	16.3	415.0	39.7	1008.6	32.4	822.7	6.3	159.0	14.6	371.0	1.8	45.0
60 cm	23.6	600.0	23.2	590.0	23.2	590.0	73.5	72.5	2.8	72.0	16.3	415.0	39.9	1013.7	33.1	840.2	6.9	176.0	14.6	371.0	1.8	45.0
62 cm	24.4	620.0	23.8	605.0	23.8	605.0	74.0	72.5	2.8	72.0	16.3	415.0	40.3	1023.4	33.8	859.3	7.6	194.0	14.6	371.0	1.8	45.0

Frame geometry subject to change

* Standover height changes significantly with tire size; our measurement is from top-center of top tube to the ground using a 700 x 25c Michelin Axial Pro tire that measured 680mm diameter on our rim

SERIAL NUMBER:

Get a pen and write down the serial number of your Surly immediately. The number is stamped into the bottom of the bottom bracket shell. Having this number is imperative if your bike ever gets stolen or if you ever have questions about your frame... we are constantly improving our products and sometimes the serial number is the only way to tell one generation of product from another.

LIMITED WARRANTY:

Surly frames and forks are guaranteed to be free from manufacturing defects for three years from the original date of purchase. What this means is that if we screwed up something in the manufacturing process that resulted in the premature failure of the product, we'll fix or replace it at our discretion. This warranty is for the original buyer of the product and is not transferable. It should go without saying that we won't even consider your warranty problem without a dated proof-of-purchase.

What this warranty doesn't cover is damage resulting from any sort of riding other than "normal" riding, and the inevitable wear and tear resulting from "normal" use. Surly products are built to be used vigorously and we wouldn't expect you to treat them gently, but we can't be responsible for the inherent danger to body and property you face each time you throw your leg over the top tube. We're hip to the "just riding along" phenomenon - and frankly, we're just not having it.

Sorry, the paintjob isn't covered, nor is any damage that happens to you or your other components as a result of any failure of one of our products. Lastly, if you modify or neglect our products we can't be responsible for them or what might happen to you while you're using them. We hate to spell it out, but hey, it's the 21st Century. We're known to back up our products, but we've seen too many peoples' parts come back to us that were not defective and did not meet our warranty guidelines. Save your self some time and shipping money by reading this and making a decision for yourself. If you and your shop think your Surly product is indeed worthy of a warranty inspection, please return the product to the original place of purchase, accompanied by a sales receipt. In the unlikely event that this is not possible, call or email us and we'll do our best to get you riding again.

OTHER PRODUCTS:

Give us a call for a free catalog or visit our website to check out all our stuff, you won't be disappointed.

CONTACT US: By all means, give us your feedback!

SURLY

6400 W. 105th St.
Bloomington, MN 55438

Phone: 877.743.3191
Web: www.surlybikes.com
E-mail: derby@surlybikes.com